

Delivering food safe freezing solutions

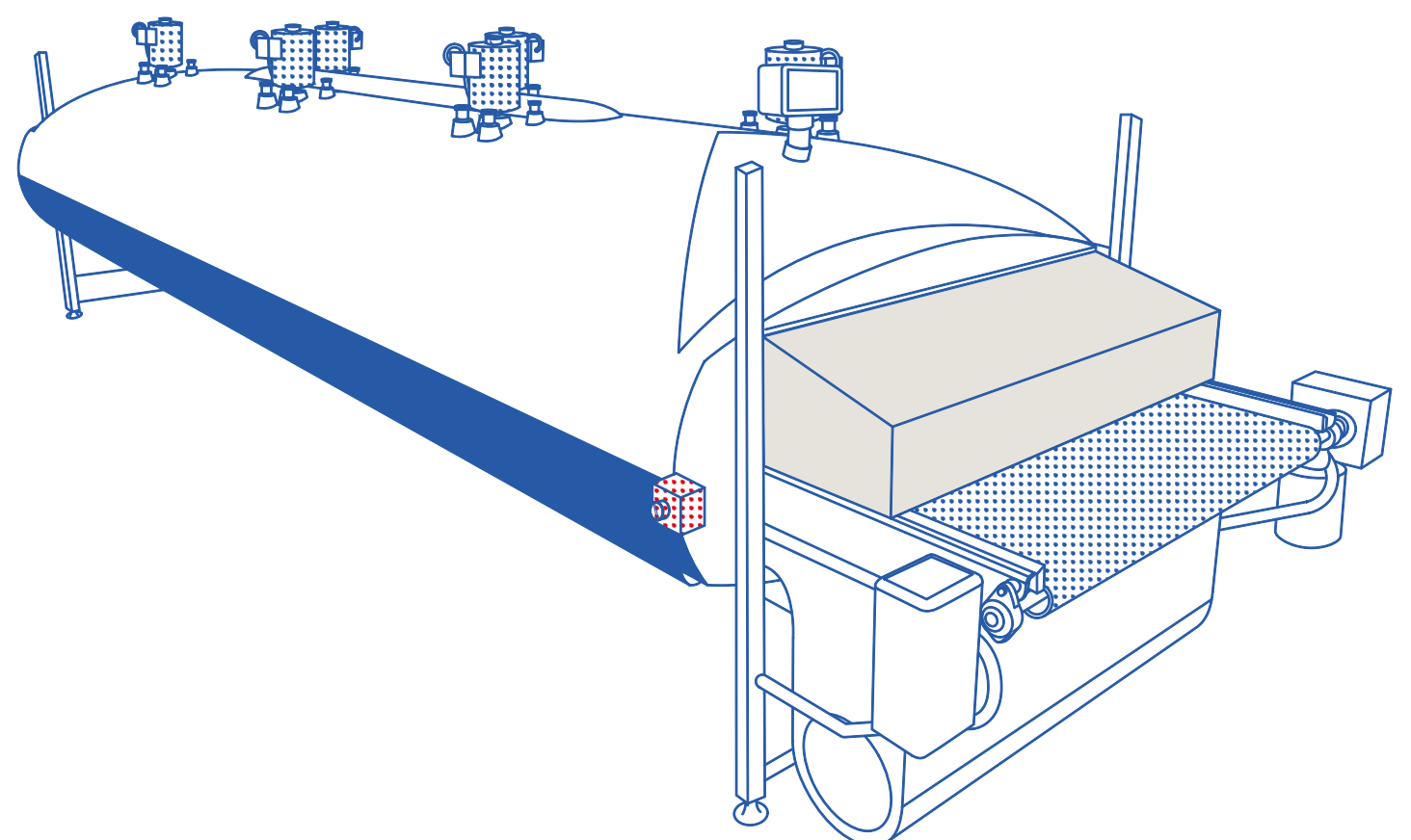

CRYO TUNNEL-AFZ combines the best of our technology and experience into a new standard for hygienically designed cryogenic food freezing equipment which uses either liquid nitrogen or carbon dioxide.

- Enhanced quality, performance and efficiency
- Designed for easier cleaning, maintenance and operation
- Improved food safety by only using food-grade compatible materials
- Certified by the USDA Dairy, Meat and Poultry Program



www.airliquide.com

Delivering food safe freezing solutions



CRYO TUNNEL-AFZ combines the best of our technology and experience into a new standard for hygienically designed cryogenic food freezing equipment which uses either liquid nitrogen or carbon dioxide.

- Enhanced quality, performance and efficiency
- Designed for easier cleaning, maintenance and operation
- Improved food safety by only using food-grade compatible materials
- Certified by the USDA Dairy, Meat and Poultry Program

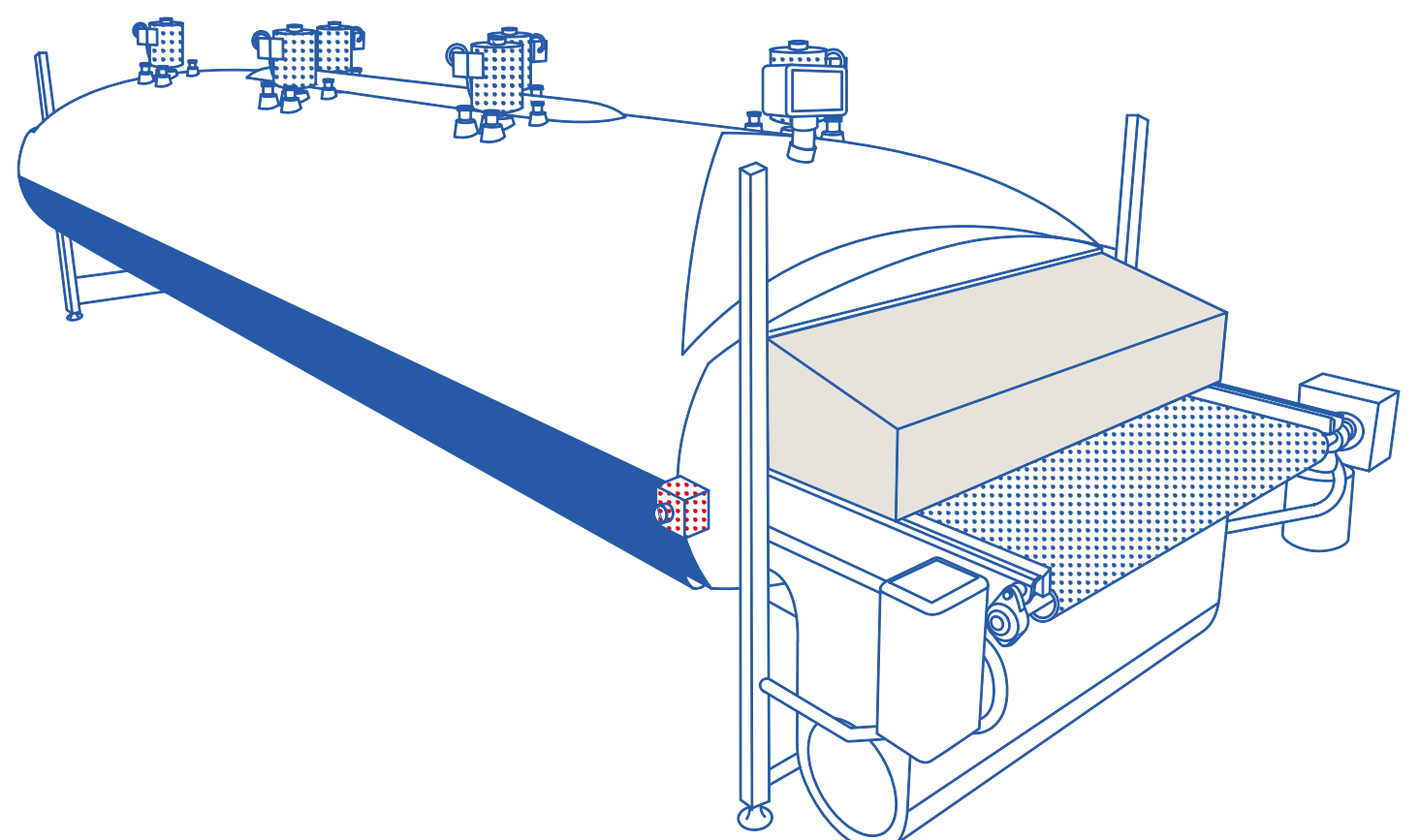

www.airliquide.com